

SUNRICHER

Bluetooth to DALI Converter

Product Datasheet

Please read all instructions before installation



Product info

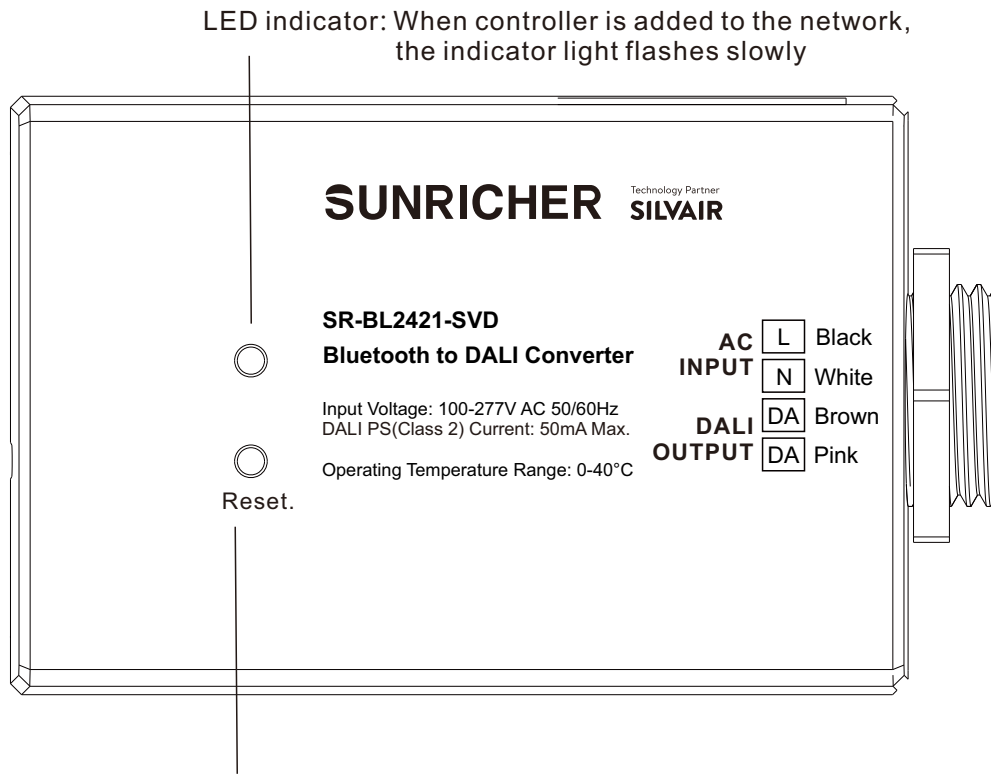

LED indicator: When controller is added to the network, the indicator light flashes slowly

Reset Key: Press it to help withdraw the device from internet/APP
LED flashes quickly indicates success.

Specification

Input		Output, DALI	Environment		Others
Power	Signal	Current	Operating temperature	Relative humidity	Size
100-277VAC	Bluetooth	Max. 50mA	0°C-+40°C	8% to 80%	82.5*55*31mm

Features

- Bluetooth to DALI signal converter, Bluetooth® mesh network
- Built-in DALI bus power supply, no additional DALI bus PS is required
- Max. 50mA DALI bus power current output, can control up to 25 DALI control gears.
- All devices on DALI line are broadcast controlled by Silvair Commissioning tools
- Mesh network, which has a much longer control distance, transmits received signals to neighbor devices
- All device on DALI line are broadcast controlled by mobile application
- Supporting our kinetic energy switches and EnOcean switches EWSSB and EWSDB
- In typical outdoor environment, the range for wireless communication is about 65meters . Actual range is dependent on field installation.
- Class 2 rated , UL listed.
- IPEX antenna
- Waterproof grade: Ip20
- 5 years warranty

Dimension

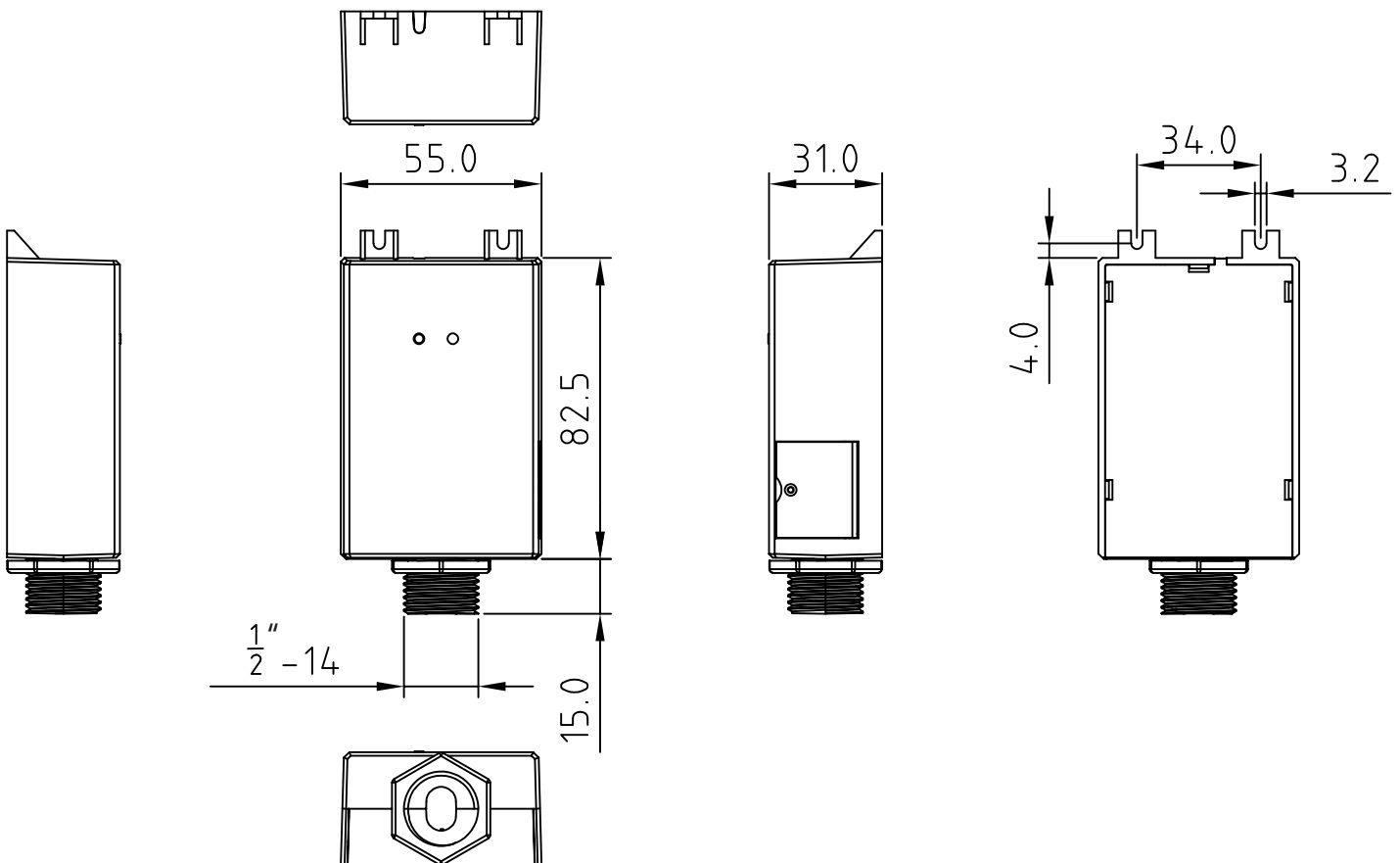

Warning

- DO NOT install with power applied to device
- DO NOT expose the device to moisture

Operation

- Do wiring according to connection diagram
- Kindly refer to " **Silvair commissioning User Manual** " for further pairing
- Press and hold down the " **Reset** " button on the controller over 5 seconds until the indicator flashes , which means it has been reset.

Installation

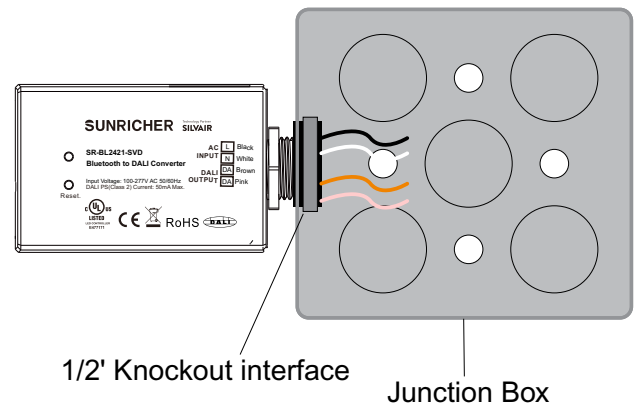
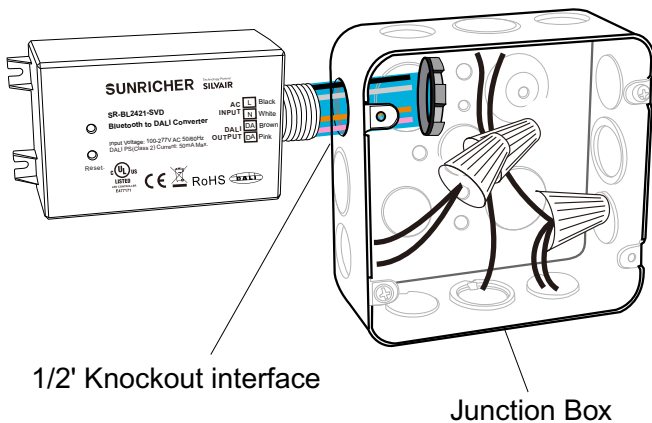

Statement

FCC STATEMENT

This equipment has been tested and found to comply with the limits for a Class B digital device, pursuant to Part 15 of the FCC Rules. These limits are designed to provide reasonable protection against harmful interference in a residential installation. This equipment generates uses and can radiate radio frequency energy and, if not installed and used in accordance with the instructions, may cause harmful interference to radio communications. However, there is no guarantee that interference will not occur in a particular installation. If this equipment does cause harmful interference to radio or television reception, which can be determined by turning the equipment off and on, the user is encouraged to try to correct the interference by one or more of the following measures:

- Reorient or relocate the receiving antenna.
- Increase the separation between the equipment and receiver.
- Connect the equipment into an outlet on a circuit different from that to which the receiver is connected.
- Consult the dealer or an experienced radio/TV technician for help.

This device complies with part 15 of the FCC Rules. Operation is subject to the following two conditions:

(1) This device may not cause harmful interference, and (2) this device must accept any interference received, including interference that may cause undesired operation.

Changes or modifications not expressly approved by the party responsible for compliance could void the user's authority to operate the equipment.

The distance between user and products should be no less than 20cm.

Wiring

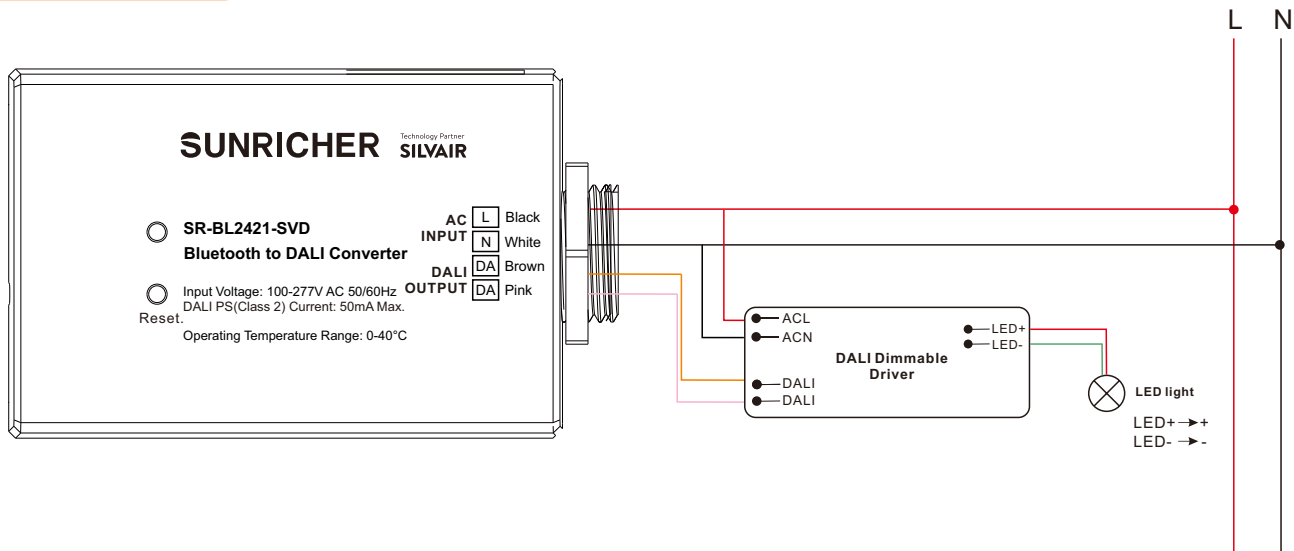

Update log

Date	Version	Update content	Update by
2022-11-11	V1.3	FCC Update	Romeo

Subject to change without notice. Please contact us if you have any question.